

LS6000 LEVEL SWITCH OWNERS MANUAL

- ◆ INSTALLATION
- ◆ CALIBRATION
- ◆ TROUBLESHOOTING
- ◆ WARRANTY

**BABBITT
INTERNATIONAL, INC.**

P.O. Box 70094
Houston, TX 77270
(713) 467-4438

TABLE OF CONTENTS

	Page
1. <u>Description</u> -----	1
<u>A. General Description</u> -----	1
<u>B. Specifications</u> -----	1
2. <u>Theory of Operation/Ordering Information</u> -----	2
3. <u>Installation</u> -----	2
<u>A. Inspection and Operation Check</u> -----	2
<u>B. Physical Installation</u> -----	2
<u>C. Removing Electronics</u> -----	3
<u>D. Typical Applications and Wiring Diagrams</u> -----	3
<u>1) LS6000 Terminal Layout</u> -----	3
<u>2) Ladder Diagrams</u> -----	5
4. <u>Calibration</u> -----	6
<u>A. Fail Safe Selection</u> -----	6
<u>B. Sensitivity Calibration</u> -----	6
5. <u>Maintenance and Troubleshooting</u> -----	7
6. <u>Warranty</u> -----	8

LS6000 LEVEL SWITCH

1. DESCRIPTION

A. General Description

The LS6000 is a point level switch that detects the presence or absence of material in a bin, silo, tank or other container. The basic unit is made up of a solid stainless steel probe attached to an explosion proof housing. Inside the explosion proof housing are all calibration adjustments and sensing electronics. The unit is calibrated in the absence of material and an internal relay changes state when material is detected.

B. Specifications

Electrical

Power:	115 VAC ($\pm 15\%$) 50/60 Hz. 2 watts, standard. (12 VDC, 24 VDC or 230 VAC optional)
Output:	2 Form C contacts, DPDT relay, 5 amp resistive
Fuse:	on board, 250 mA
Fail Safe:	Selectable high or low level
RF Frequency:	Approximately 1.3 MHz

Environmental

Hazardous Area:	Class I, Group D, Class II, Group E, F, G
Temperature:	Probe: -30° F to 250° F Electronics: -40° F to 185° F
Pressure:	Probe: 1500 psi @ 75° F. Higher ranges available on request.
Construction:	Probe: All wetted parts, 316 SS, Delrin and Viton. A Halar coating can be applied to the probe when applicable. Electronics: Housed in cast aluminum explosion proof enclosure.

Specifications subject to change without notice.

C. Ordering Information

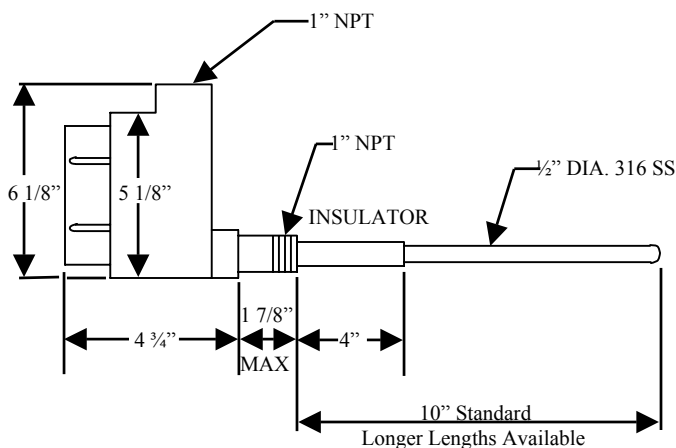
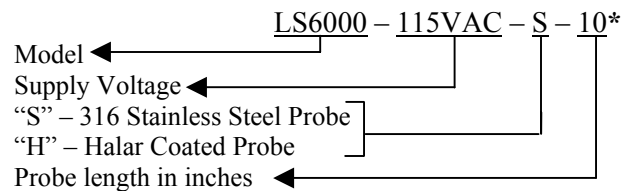

FIGURE 6.1



*This describes an LS6000, powered by a 115 VAC, with a 316 SS probe, 10" long. The probe length is measured from the end of the nipple to the tip of the probe.

2. THEORY OF OPERATION

The LS6000 employs a radio frequency (RF) balanced impedance bridge circuit to detect if the probe is in contact with the material that is to be sensed.

When material is not in contact with the probe, the bridge is balanced by turning the adjustment pot to find the threshold where the red led goes out.

When material is in contact with the probe, the bridge becomes unbalanced and the comparing circuit realizes the change. This causes the relay to change state.

3. INSTALLATION

***CAUTION:** ALL INSTALLATION AND WIRING MUST CONFORM TO NEC AND ALL OTHER LOCAL ELECTRICAL CODES. TAKE SPECIAL CARE IN OBSERVING HAZARDOUS AREA SAFETY PROCEDURES. WE ASSUME NO LIABILITY FOR IMPROPERLY INSTALLED OR WIRED UNITS.

A. Inspection and Operation

After unpacking the LS6000, visually inspect the unit for any damages.

Please advise the factory or your local distributor of any damage.

Before installing the unit, a simple operational check can be performed.

On the bench, hook up the appropriate power to L1 and L2. The operating voltage of the LS6000 is marked on the power supply board.

Hold the unit so that the probe is not touching any surface and touch the probe.

When you touch the probe, the red led should come on. This simulates product touching the probe.

B. Physical Installation

- 1) The LS6000 is installed into the vessel wall using a 1" NPT connection. This can be either a threaded coupling or a tapped entry such as a flange.
- 2) The insulator should always extend at least 2" through the vessel wall.
- 3) Always check for physical room around the location you have chosen to allow for installation. Allow 3.25" turning radius to screw the probe in and clearance above for the length of the probe.
- 4) **CAUTION:** Always take the necessary safety precautions when cutting or welding in the coupling for the LS6000.
 - a) Tag and lock out the electrical power to the equipment that services the vessels.
 - b) Check liquid or dry powders that create a gas in the vessel for oxygen as well as the explosion factor. (All dust will explode.)
 - c) Vessels that are cross vented have to be isolated.
- 5) Screw the LS6000 into the connection provided. In dry material application, no sealant on threads is required. On liquid, teflon or a good pipe thread sealant may be used.
- 6) The LS6000 has a 1" NPT conduit entry. When wiring these units, conform to the National Electrical Code and any other city or company codes.
- 7) Always install the electrical connection to the 1" NPT conduit entry so that water will not follow the connection routing into the threads of the conduit hub. To guarantee that condensation and water will stay outside the unit, install an EYSM unilet before each LS6000 and fill with explosion proof sealing cement.
- 8) When required, the LS6000 probe can be bent to meet your special application. Remember to allow 2" of clearance between the probe and the vessel wall. If the probe is to be used in a pressure application, the factory must bend the probe to your specifications.
- 9) Location of probes on high level installations is more critical on dry material than liquids. Note the following:
 - a) For dry materials, mount the LS6000 in the top of the vessel whenever possible. (This allows you to lengthen the probe if necessary.)
 - b) Avoid mounting the LS6000 near the product inlet, vent return lines, dust collectors and vessel discharge openings on dry materials. Turbulence around these areas can cause erratic detection unless the probe is long enough. On old installations it might be wise to fill the vessel first to determine the length or location of the probe. **CAUTION:** Always take safety precautions before opening vessels for such inspection.
 - c) On gravity filled vessels, take into consideration the angle of repose formed by the product.

- d) On dry product that flows like water (starch), when using the LS6000 to stop the flow by means of a butterfly valve or knifegate, make sure the probe is long enough to allow time to close these slow moving valves.
- e) In small vessels where a good location is hard to find, it may be necessary to put a baffle plate between the probe and the product inlet to keep product off of the probe as it fills.

C. Removing the Electronics

- 1) Disconnect supply power at main power source.
- 2) Disconnect wires from terminal strip.
- 3) Unplug blue antenna lead.
- 4) Remove green grounding screw.

D. Typical Applications and Wiring Diagrams

As follows:

LS6000 TERMINAL LAYOUT

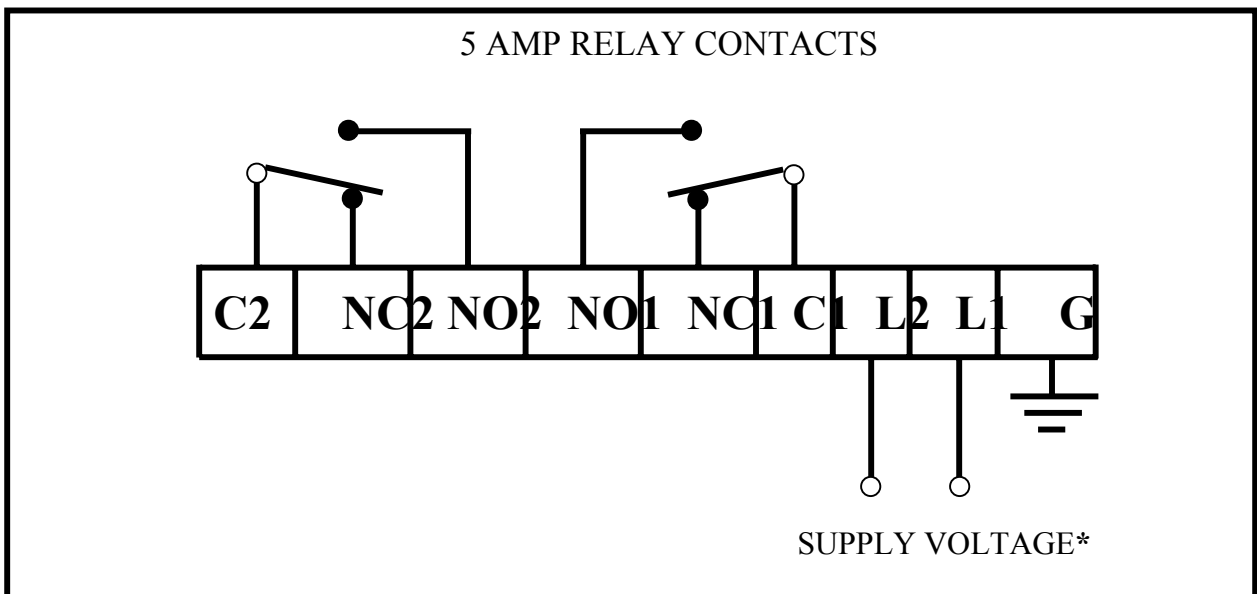

***NOTE:** EACH LS6000 POWER SUPPLY IS INTENDED FOR ONLY ONE SUPPLY VOLTAGE. THIS VOLTAGE IS PRINTED ON THE POWER SUPPLY BOARD. FOR 115 VAC OR 230 VAC UNITS, HOOK UP THE HOT LEAD TO L1 AND THE NEUTRAL TO L2, WITH APPROPRIATE GROUND. FOR 12 VDC OR 24 VDC UNITS, HOOK THE POSITIVE VOLTAGE TO L1 AND THE COMMON OR GROUND TO L2.

FIGURE 6.2

LS 6000 ELECTRONIC BOARD

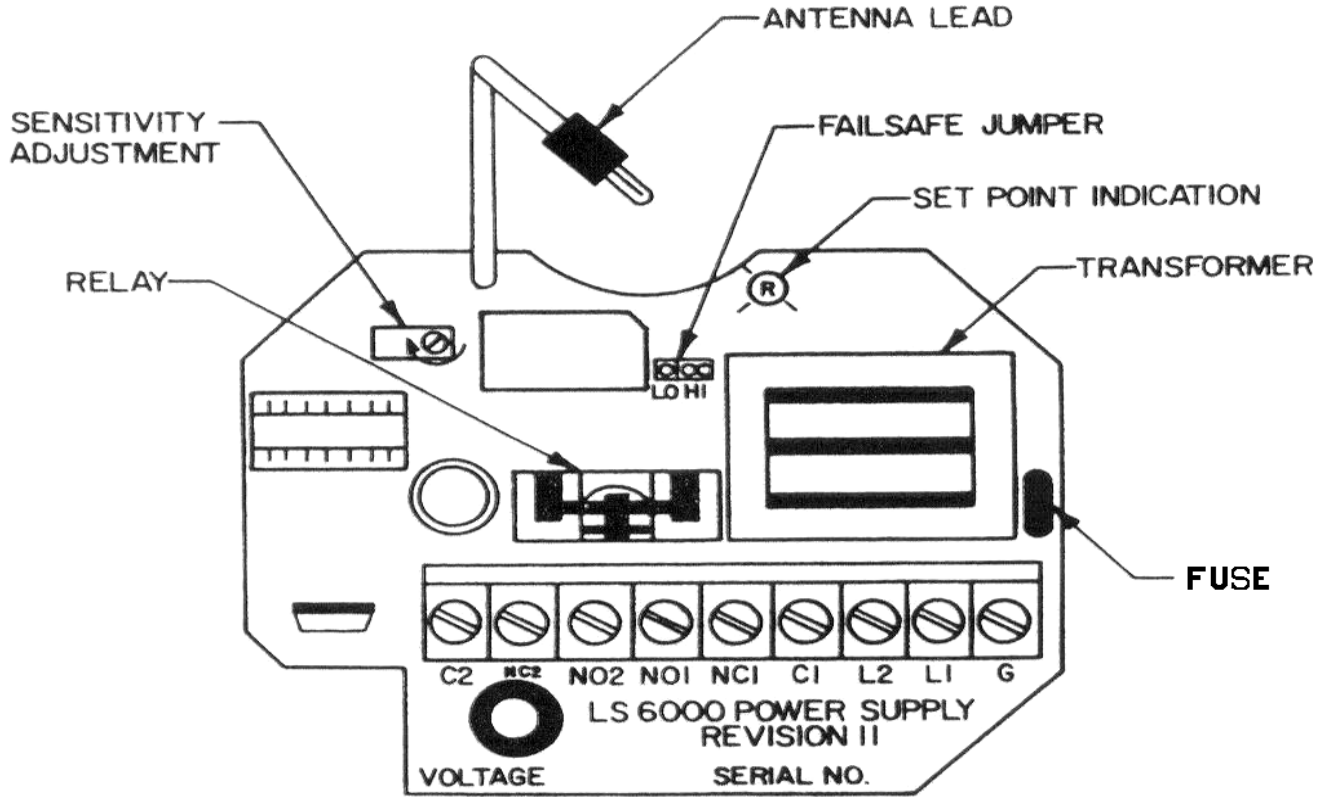
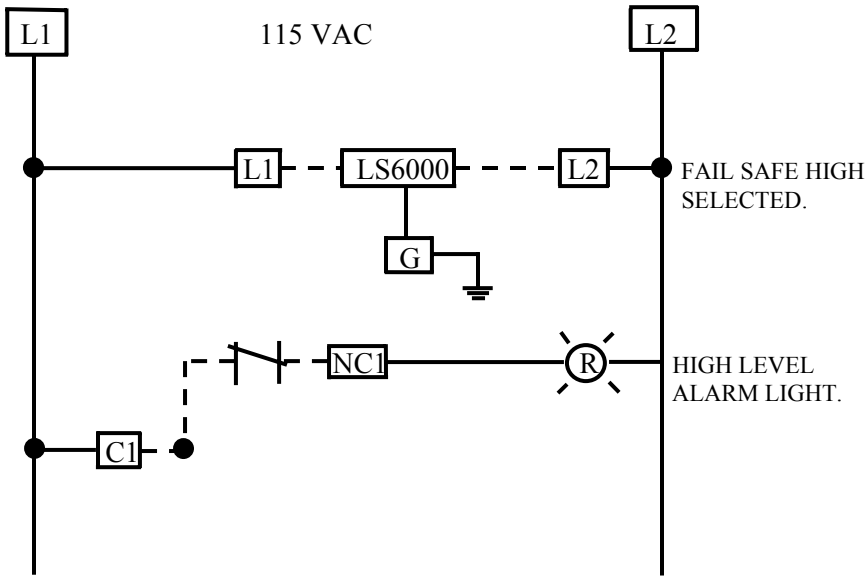

FIGURE 6.3

TYPICAL WIRING



NOTE: PLEASE REVIEW FAIL SAFE INSTRUCTIONS, (SEC. 4A)

APPLICATION
HIGH LEVEL ALARM

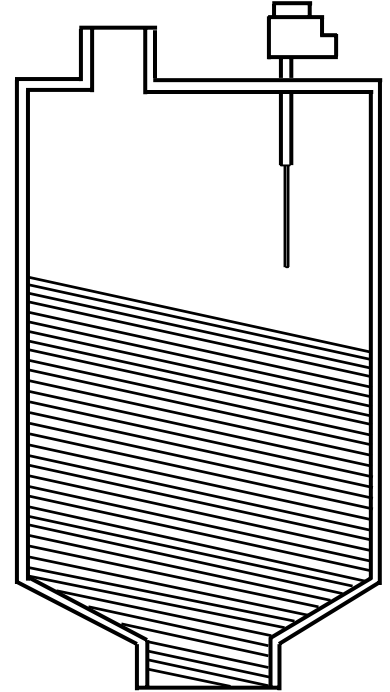
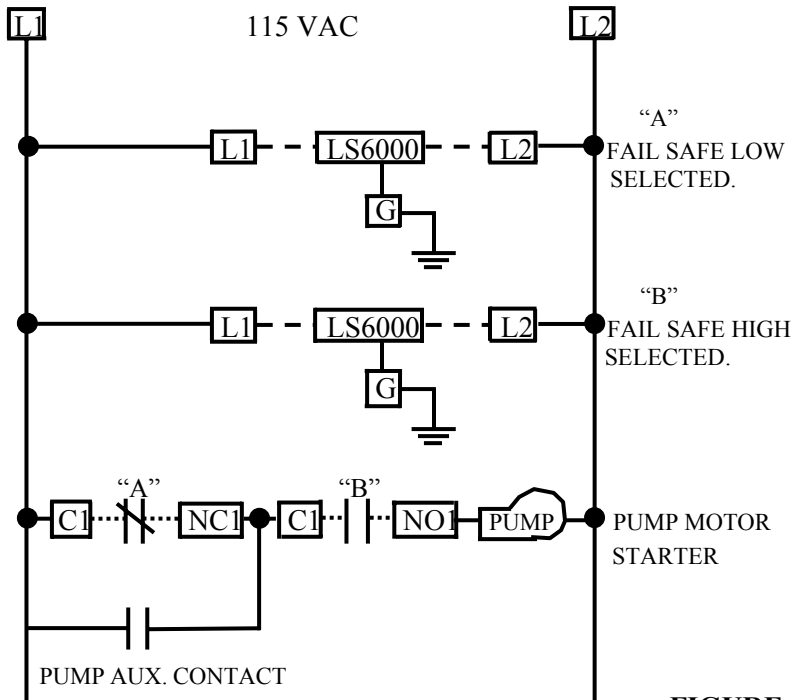

FIGURE 6.4

TYPICAL WIRING



PUMP AUX. CONTACT

APPLICATION

AUTOMATIC FILLING OF TANK.
(WHEN LEVEL FALLS TO POINT "A",
A PUMP COMES ON TO FILL TO
POINT "B", THEN TURNS OFF.)

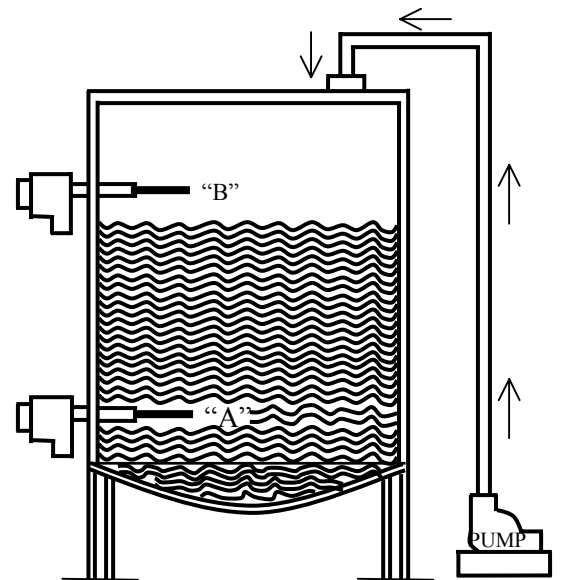

FIGURE 6.5

4. CALIBRATION

PLEASE READ THE ENTIRE CALIBRATION PROCEDURE BEFORE CALIBRATING THE LS6000.

A. Fail Safe Selection

The fail safe feature provides a “false alarm” in case of power outage or major component failures. When properly selected, the fail safe feature can protect equipment or alert you of a unit failure.

Fail Safe High (FSH) means that the relay is energized when NO PRODUCT is touching the probe. When product comes into contact with the probe, the relay is de-energized.

Fail Safe Low (FSL) means that the relay is energized when PRODUCT IS touching the probe.

Fail Safe High or Fail Safe Low is selected by plugging the jumper near the transformer in the appropriate position. (See diagram pg. 4)

NOTE: Due to the wide variety of applications and possible control or alarm functions, the proper fail safe selection will depend on your circumstances. Please call your distributor or the factory if you need assistance.

B. Sensitivity Calibration

The LS6000 should be calibrated when no material is touching the probe and when the unit is installed where it will be used.

- 1) Observe the red LED. If it is on, go to step 3.
- 2) If the red LED is off, turn the sensitivity adjustment potentiometer clockwise (CW) until it comes on.
- 3) Turn the sensitivity adjustment pot counter-clockwise (CCW) until the red LED just goes out. This sets the unit to its maximum sensitivity. If in your application this is too sensitive, you can turn the sensitivity adjustment pot further CCW. Always bring the product into contact with the probe after calibration to assure proper performance.
- 4) The factory or your local distributor can answer any questions you may have about calibration.

Every LS6000 has a diagram inside the screw cover to serve as a reminder to those who have calibrated the unit before. This shows the calibration adjustments and indicators. This diagram is reproduced below.

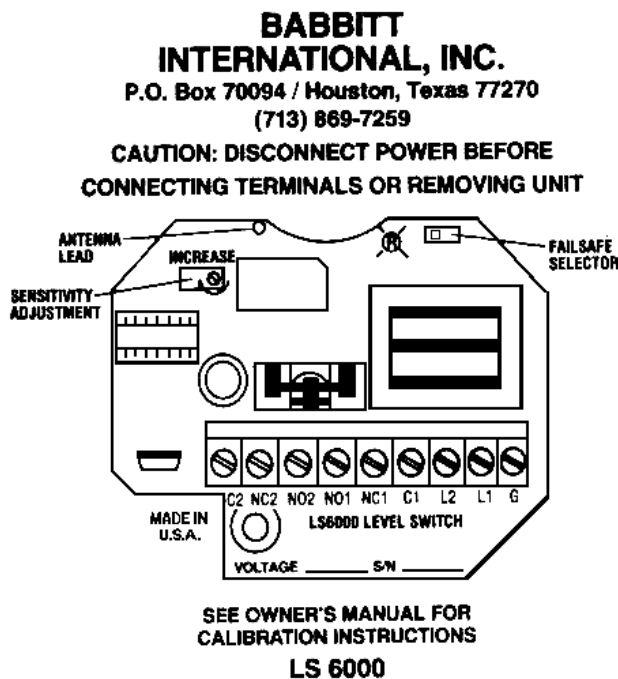

FIGURE 6.6

SPECIAL CALIBRATION NOTES:

For some products, the LS6000 can be calibrated with product touching the probe. To do this, turn the sensitivity adjust pot CW until the red LED just comes on and continue CW for 1/8 to 1/4 of a turn. Always check to see if the unit resets in the absence of product.

INTERFACE CALIBRATION

For applications such as an oily water interface, the unit should be calibrated in the less electrically conductive fluid (oil) and the unit will then “ignore” the oil, but sense the water.

5. MAINTENANCE AND TROUBLESHOOTING

No routine maintenance is required other than keeping the interior of the unit clean and free of dirt, dust and other contaminants.

The LS6000 consists of three main sub-assemblies. These are the enclosure, the antenna probe and the electronics. The following troubleshooting guide will assist in determining how to correct most of the problems which may occur in sections 3 and 4.

PROBLEM	POSSIBLE CAUSE	SOLUTION
RED LED cannot be adjusted to turn on.	Antenna lead not connected No power to unit. Bad electronic card.	Plug antenna lead into probe. Check for correct power to unit. Repair or replace card.
RED LED remains on at all times	Antenna probe is shorted to case or ground. Bad sensing card.	Unplug banana plug and position it so that the bare end is not touching anything. Turn calibration pot 20 turns CCW. LED should go out. If it does, repair, replace or clean antenna probe. If LED does not go out, replace electronics. Repair or replace card.
Unit triggers when material touches probe, but will not reset when material recedes from probe or unit and gives false alarm.	Improper mount of probe. Improper calibration procedure. Excessive material build-up on probe. Probe is mounted in flow of material.	Contact factory or dist. See section 4B. Perform “dirty probe calibration”: Recalibrate with built up material on probe. See section 4B. Revise mounting.
Unit will not detect material.	Improper calibration. Antenna lead not plugged into probe. Unit was calibrated with material touching probe.	See calibration instructions, section 4. Plug antenna lead into probe. Be sure material is not touching probe and recalibrate.
Unit will not stay in calibration.	Poor grounding of unit to vessel.	Provide secure ground connection.
Relay operates properly, but no signal at terminals.	Burned or broken lands on the printed circuit board. Bad relay contacts.	Turn off power. Remove module from housing and inspect lands on printed circuit for damage. Replace if necessary. Replace relay or return for repair.

PLEASE CONTACT THE FACTORY OR YOUR DISTRIBUTOR IF YOU HAVE ANY QUESTIONS OR NEED ASSISTANCE.

6. WARRANTY

All components of the LS6000 are warranted to be free from defects in material and workmanship for a period of two years from the date of purchase . This warranty applies to general purchaser and to components installed, serviced and operated according to instructions.

Babbitt International, Inc. will repair or replace, at its option, FOB at its plant or any other location designated, any part which proves to be defective in manufacture or workmanship.

All claims must be made in writing within the warranty period. No claims outside of the warranty period will be honored.

Warranties are not applied to any components which have been damaged by improper installation, use, exposure to unusual atmospheric conditions or components which have been misused, abused, damaged by neglect or accident. This warranty shall not apply to any components which have been altered or repaired without the prior written consent of Babbitt International, Inc.

Babbitt International, Inc. assumes no responsibility or liability for any labor or material back charges, without written authorization. Any products returned must be with prior written authorization.

THE FOREGOING IS IN LIEU OF ALL OTHER WARRANTIES, EXPRESSED OR IMPLIED, INCLUDING ANY WARRANTIES OF MERCHANTABILITY AND/OR FOR FITNESS FOR PARTICULAR PURPOSE, AND BABBITT INTERNATIONAL, INC. ASSUMES NO OTHER LIABILITIES EXPRESSED OR IMPLIED. BABBITT INTERNATIONAL, INC. SHALL NOT BE LIABLE FOR NORMAL WEAR AND TEAR, NOR FOR DIRECT, INCIDENTAL OR CONSEQUENTIAL DAMAGES. IN NO EVENT SHALL BABBITT INTERNATIONAL INCORPORATED'S LIABILITY EXCEED THE PRICE OF ITS PRODUCT AT THE TIME OF PURCHASE.